

PIKE COUNTY TICK BORNE DISEASES TASK FORCE

A Committee of the Pike County Commissioners Office

506 Broad Street
Milford, PA 18337

Phone # 570-296-3569

Fax # 570-296-6055

Symposium on Tick Borne Diseases: An Endemic Crisis

AGENDA: October 10, 2015, 8:30 AM – 12:30 PM

Pike County Training Center, Lords Valley, Pennsylvania

Moderator: **John H. Klemeyer, Esq.**

8:30 AM – 9:00 AM

Registration & Refreshments

9:00 AM – 9:05 AM

Welcome and Introductions

Richard A. Caridi, Pike County Commissioner and Chairman

Matthew M. Osterberg, Pike County Commissioner

Karl A. Wagner, Jr., Pike County Commissioner

9:05 AM – 9:30 AM

What are Tick Borne Pathogens?

Presenter: **Jane E. Huffman, PhD**

- ❖ Director, East Stroudsburg University Wildlife DNA Laboratory
- ❖ Commonwealth of Pennsylvania Department of Health's Tick and Lyme Diseases Task Force

9:30 AM – 9:40 AM

Humans and Tick Borne Infections

Presenter: **Robert-A. Ollar, PhD**

- ❖ Microbiologist
- ❖ Commonwealth of Pennsylvania Department of Health's Tick and Lyme Diseases Task Force
- ❖ Pike County Tick Borne Diseases Task Force

9:40 AM – 10:15 AM

How Tick Borne Diseases are Currently Diagnosed and Treated

Presenter: **Sami F. Yasin, MD**

- ❖ Physician, Internist Specializing in Infectious Disease Medicine

10:15 AM – 12:15 PM

Controversies Surrounding Tick Borne Diseases

Presenter: **Gregory P. Bach, DO**

- ❖ Family Practice Physician, Specializes in Tick Borne Diseases and Addiction Medicine
- ❖ Commonwealth of Pennsylvania Department of Health's Tick and Lyme Diseases Task Force

12:15 PM – 12:30 PM

Questions and Answers

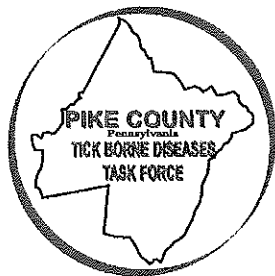

PIKE COUNTY TICK BORNE DISEASES TASK FORCE

A Committee of the Pike County Commissioners Office

506 Broad Street
Milford, PA 18337

Phone # 570-296-3569

Fax # 570-296-6055

CALL FOR ACTION

Pennsylvania is Currently an Endemic Area for Tick Borne Diseases

The US Senate has introduced, in June of 2015, Senate Bill 1503 (Blumenthal Bill) which will focus upon:

1. Funding education of physicians and the public on tick borne diseases.
2. Support research on newer more accurate technologies for:
 - a) Early and specific direct detection of tick borne pathogens
 - b) Quantitative monitoring of pathogenic carriage in ticks
 - c) Direct monitoring of pathogen clearing due to antibiotic therapy
 - d) Surveillance of ticks
 - e) Creation of a national database
3. Create a Federal Committee or Task Force to deal with nationwide policies in how to deal with all issues related to tick borne diseases.

Problem with Senate Bill 1503 is that it is looking at issues associated with tick borne disease policies in the future on a national level and does *not* address the current TBD epidemic. The US Senate has NOT even passed this bill at this point in time.

Tick Borne Epidemics are currently plaguing states, like Pennsylvania, where tick related infections have become endemic.

Pennsylvania has created a State Task Force and local counties, like Pike County, have created their own model programs.

The common denominator in the state and county programs is that there currently is no available funding to provide for the much needed programs that address the issues associated with:

- a) Education and certification of physicians who are responsible for early diagnosis and treatment of patients. This is needed because, in the current scenario, our local physicians are, in many cases, totally unqualified to treat and understand the patients and their problems associated with tick borne diseases.

- b) Education of the public on ways to better understand and prevent tick borne infections.
- c) Provide for surveillance of pathogen carriage in ticks and human victims of tick bites.
- d) Create computer based files on the specific pathogens associated with tick bite victims on a county by county basis.
- e) Fund research programs to find improved technologies to more rapidly diagnose and correctly treat tick borne diseases and their long range consequences.

Current crisis faced by Pennsylvania and other states where tick borne diseases have now become endemic have reached the crisis point and must be addressed without any further delay.

The tick borne epidemic in Pennsylvania has reached the crisis level. Pennsylvania *must* be given financial support from the federal government to deal with this problem without delay.

What must be done to get things moving to deal with this public health menace with dispatch?

Our Governor has the ability to declare Pennsylvania a *Disaster Area* due to **Tick Borne Diseases.**

The Governor can demand federal funding in the form of block grants to support the essential programs necessary to properly address and control this menace. This is as much a crisis as was the recent hurricanes that greatly damaged many regions of Pennsylvania.

In the history of medical science, diseases were managed and eventually defeated when they were fought with the best available and properly funded professionally trained staff equipped with the latest technologies.

Public Health affects all of our citizens, and the well-being of the economy of our state and nation. Public Health is not the domain of a few special interests based upon their selfish aims.

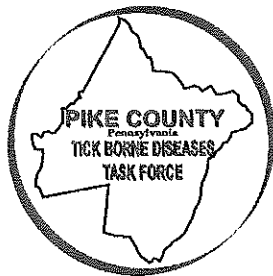

PIKE COUNTY TICK BORNE DISEASES TASK FORCE

A Committee of the Pike County Commissioners Office

506 Broad Street
Milford, PA 18337

Phone # 570-296-3569

Fax # 570-296-6055

OVERVIEW OF PIKE COUNTY TICK BORNE DISEASES TASK FORCE (PCTBDTF)

In July 2013, some concerned citizens, including educators and people from the medical field, formed the *Pike County Lyme Disease Task Force*, now known as the *Pike County Tick Borne Diseases Task Force (PCTBDTF)*, to bring awareness to Pike County residents the complexity of the issues and ways in which more effective medical treatment can be obtained for tick borne diseases. There was also a need to develop comprehensive mechanisms to suppress the tick population. This alliance initially came about during a meeting of the minds of Mikki Weiss, Educational Consultant, and Marty Theys, Facilitator, Sussex County Tick Borne Diseases Support Group. They are very well aware of the situation both being victims of tick borne diseases.

Soon three other members joined: Jim McCaw, Educator; Sandy McCaw, RN, Certified Life Coach; and Jeff Rosalsky, Executive Director, Pocono Environmental Education Center (PEEC). Shortly afterwards, Clare Bennett, President, Board of Directors, Birchwood Lakes Community Association, joined. Assisting the Task Force is educator Fay P. Lukin as Communications Consultant.

On June 7, 2014, the *PCTBDTF* provided an educational seminar to the *Alliance of Community Associations (AOCA)* and other Pike County residents on tick borne diseases. An article reporting the success of the seminar appeared in the *Pike County Dispatch* newspaper which resulted in Dr. Robert-A. Ollar contacting the *PCTBDTF* and expressing a desire to work with the *PCTBDTF* and add his expertise in researching tick borne diseases. On August 20, 2014, the *PCTBDTF* and consultant, Robert-A. Ollar, PhD, internationally respected Microbiologist, attended the Pike County Commissioners' meeting and presented an overview of the complexity of dealing with tick borne diseases. As a result of the meeting, the *PCTBDTF* gained the support and encouragement of the Pike County Commissioners (Richard A. Caridi, Matthew M. Osterberg, Karl A. Wagner, Jr) for its mission.

The Commissioners, concerned about Pike County residents, acknowledged the endemic crisis in the community and embraced it as a county issue. On May 20, 2015, the Commissioners passed a resolution that appointed the *Pike County Tick Borne Diseases Task Force*, a volunteer committee, as an education arm of the County to provide up-to-date information as to **prevention, diagnosis and treatment** of tick borne illnesses. The current *PCTBDTF* members are Deborah Albrecht, Clare Bennett, Meaghan Butler, Jill Gamboni, Nancy Grotevant, John H. Klemeyer, Jim McCaw, Sandy McCaw, Michael Mrozinski, Robert-A. Ollar, Jeff Rosalsky, Marty Theys, Mikki Weiss and Barbara Thomsen Whitney.

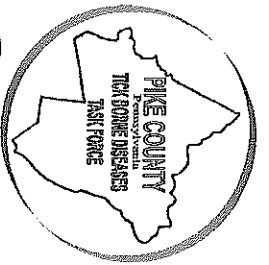

Pike County Tick Borne Diseases Task Force NETWORKING and ARTICULATION CHART

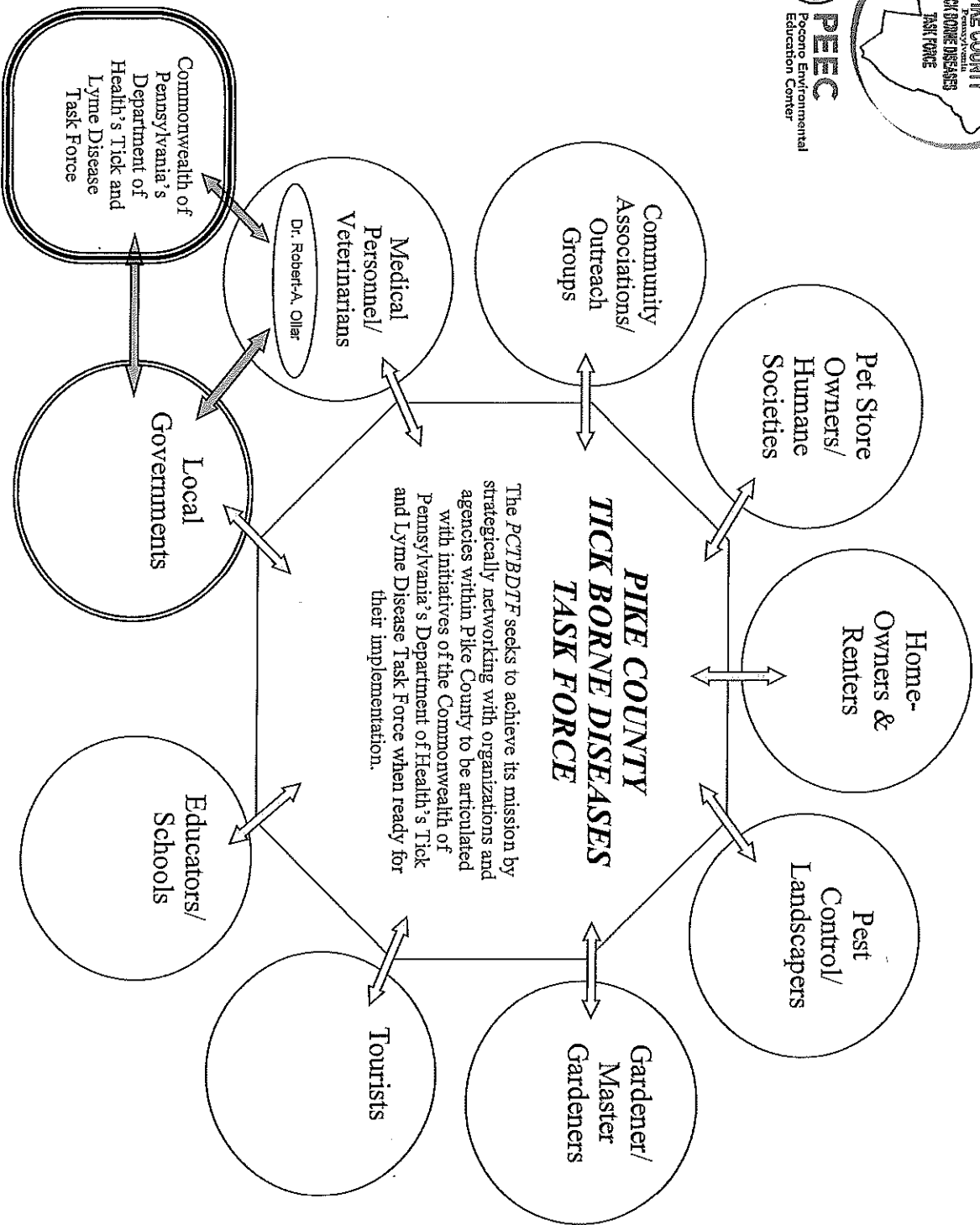

PCTBDTF FOCUS MEETING: October 30, 2014 - 10:00 AM at Pocono Environmental Education Center (PEEC), Dingmans Ferry, PA

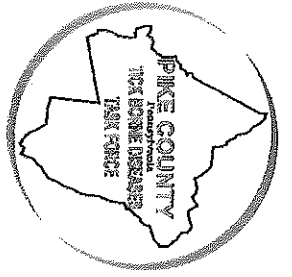

PIKE COUNTY TICK BORNE DISEASES TASK FORCE

A Committee of the Pike County Commissioners Office

506 Broad Street
Milford, PA 18337

Phone # 570-296-3569

Fax # 570-296-6055



Year End Report: Development of STEP for Pike County STEP: Sustainable Tick borne diseases Education Program

Designed to Address Prevention, Diagnosis and Treatment of TBD

December 2015

This concludes the first phase of the Pike County STEP initiative.

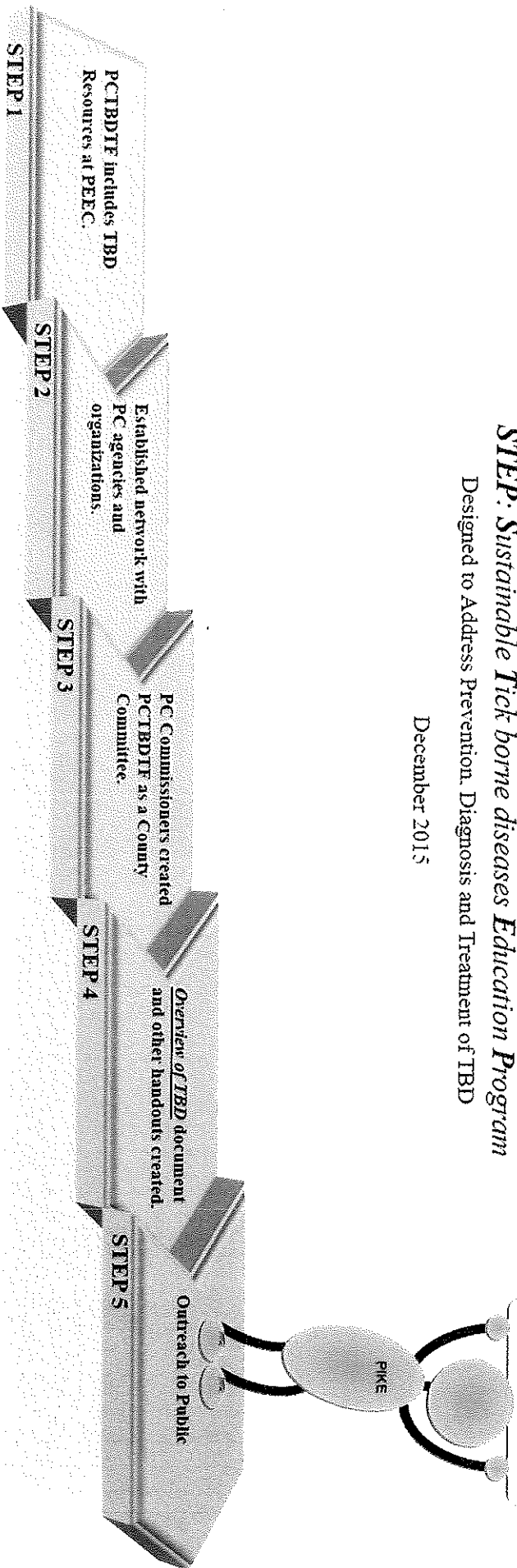

- STEP 1**

Rationale: Barrier able to deal with environmental aspects & mitigation of ticks.

TF & EST: DVA Lab conducted activities, at PEEC, addressing ecology; prevention & mitigation of ticks.
- STEP 2**

Rationale: Ability to implement an effective digital outreach to most of county population.

Connected with PC agencies, organizations (including AOCFA), township representatives, Penn State Extension, school districts' representatives.
- STEP 3**

Rationale: This will allow the best chance for making STEP work for the greatest number of Pike Residents.

TF Committee updated public at Commissioners' monthly meetings and made presentations to varied organizations.
- STEP 4**

Rationale: Need to create handouts on materials presenting the big picture for public distribution.

Created distributed varied materials addressing prevention, diagnosis, treatment and mitigation presenting both sides of controversy and complexity.
- STEP 5**

Rationale: The need for public awareness of the complexity and lack of protocols for effective diagnosis, treatment & monitoring of TBD.

In October 2015, a panel of medical specialists & scientists presented "Symposium on TBD: an Endemic Crisis" clarifying the underpinnings of the complexity of human TBD & the environmental relationship.

Design Concept by Mikki Weiss, MA, Educational Consultant

Graphics by Fay P. Lutkin, MSED, PD, Educational Consultant

PIKE COUNTY TICK BORNE DISEASES TASK FORCE

A Committee of the Pike County Commissioners Office

506 Broad Street
Milford, PA 18337

Phone # 570-296-3569

Fax # 570-296-6055

STEP: Sustainable Tick Borne Diseases Education Program for Pike County

Design Concept by Mikki Weiss, MAEd, PCTBDTF Committee Chair

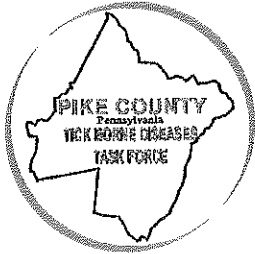

- ✿ Realizing the need for a Task Force, Mikki Weiss, in 2013, conceptualized and established the Pike County Tick Borne Diseases Task Force (PCTBDTF). In concert with Marty Theys and three other people, the TF began its mission to provide information regarding prevention, diagnosis and treatment of TBD to the residents of Pike County (Pennsylvania).
- ✿ PCTBDTF & East Stroudsburg University DNA Lab conducted activities, at PEEC, addressing ecology, prevention & suppression of ticks and host organisms.
- ✿ PCTBDTF began networking with PC agencies, organizations, township representatives, Penn State Extension, school districts' representatives providing workshops and outreach initiatives.
- ✿ On May 20, 2015, the Pike County Tick Borne Diseases Task Force became a voluntary education committee of the Pike County Commissioners Office. The Committee includes the Pike County Commissioners, state representatives, educators, scientists, lawyers, business people and community members. The STEP endeavor was created, by Mikki Weiss, and implemented by the PCTBDTF.
- ✿ Based on PA General Assembly 2014 Act 83 along with its recommendations, in October 2015, PC Commissioners and the PCTBDTF assembled a panel of medical specialists & scientists, in Pike County, focused on clarifying the underpinnings of the complexity of human TBD & the environmental relationship at the "Symposium on Tick Borne Diseases: An Endemic Crisis."



- ☎ Our Pike County Tick Borne Diseases Support Group provides hope for people with TBD and their families: sharing experiences, coping strategies and acquiring positive attitudes towards better health. The Group meets the second Saturday of each month.

Tick Borne Diseases Resources



at
PEEC
Pocono Environmental
Education Center

- ✿ Tick Borne Diseases Resources at PEEC (Pocono Environmental Education Center) provides environmental materials and activities, for different age groups, to address TBD ecology, prevention and suppression of tick and host populations.

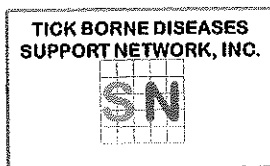

- TBD Support Network, Inc., dedicated to serving those with tick borne diseases, was established to provide knowledge, research, education and resources to obtain a better quality of life by management of the diseases. We are a 501(c)(3) nonprofit organization.

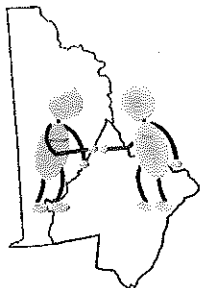

- ❖ The Pike County - Wayne Memorial Hospital Connection: *Wayne - Pike Tick Borne Diseases Emotional Support Group* is slated to start July 11, 2016.

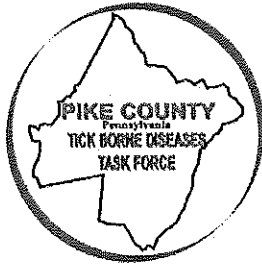

PIKE COUNTY TICK BORNE DISEASES TASK FORCE

A Committee of the Pike County Commissioners Office

506 Broad Street
Milford, PA 18337

Phone # 570-296-3569

Fax # 570-296-6055

Symposium on Tick Borne Diseases: An Endemic Crisis

October 10, 2015, 8:30 AM - 12:30 PM

Pike County Training Center, Lords Valley, Pennsylvania

OBJECTIVES

1. To understand how tick borne diseases are transmitted.
2. To realize that Lyme disease is only one infection and *not* a synonym for all infections associated with a tick bite.
3. To address issues for need of earlier, more effective diagnosis, treatment and monitoring of tick borne pathogens.
4. To be aware of complex controversies associated with diagnoses and treatments for tick borne diseases.

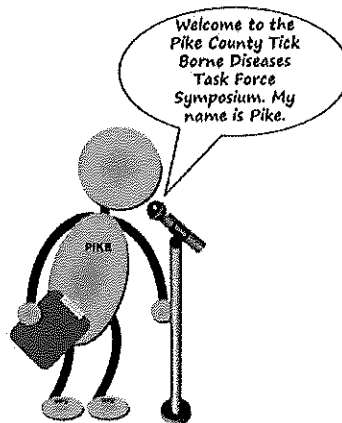

Lyme Disease Defined

By Robert-A. Ollar, PhD

Member, Pennsylvania Department of Health's Tick and Lyme Disease Task Force

Member, Pike County Tick Borne Diseases Task Force

The Centers for Disease Control and Prevention (CDC) website states "Lyme disease is caused by the bacterium *Borrelia burgdorferi* and is transmitted to humans through the bite of infected blacklegged ticks. Typical symptoms include fever, headache, fatigue, and a characteristic skin rash called erythema migrans. If left untreated, infection can spread to joints, the heart, and the nervous system. Lyme disease is diagnosed based on symptoms, physical findings (e.g., rash), and the possibility of exposure to infected ticks."

Lyme disease therefore is an infection caused by a specific pathogen. In this context it must be always understood that Lyme disease is **not** a synonym for all pathogens carried by ticks.

This is why the proper terminology must be Tick Borne Diseases when referring to infections associated with at tick bite.

A tick can carry multiple pathogenic organisms (bacterial, parasitic, and viral), and thus a tick bite can inflict multiple and varied pathogen events. It must be always remembered that all pathogens carried by ticks are equally dangerous in their ability to inflict disease to their victim.

Each tick bite is a unique event, and as such, it we must never automatically assume that we are treating a single specific pathogen. In addition, it must also be realized that a tick bite does *not* have to automatically harbor the Lyme bacteria, *Borrelia burgdorferi*.

Concluding Remarks

Therefore, one must **never** take a generic approach in our treatment of a pathogen or pathogens acquired by a tick bite.



**TICK BORNE DISEASES
(TBD)
SUPPORT NETWORK, INC.**

MEETS

**SECOND SATURDAY OF
EACH MONTH**

10:30 AM - 12:00 PM

at

**PIKE COUNTY PUBLIC LIBRARY
119 HARFORD ST
MILFORD, PA 18337**

For Additional Info, Phone the Hotline # 570-503-6334

Join Robert-A. Ollar, PhD; Marty Theys; and Mikki Weiss, MAEd

~ Share Experiences ~ Learn About Current Research ~ Guest Speakers

Our Support Network is for People with Tick Borne Diseases and Their Families

TBD Support Group is Now the TBD Support Network: Please Join Us



PIKE COUNTY
TICK BORNE DISEASES TASK FORCE
 A Committee of the Pike County Commissioners Office

506 Broad Street
 Milford, PA 18337

Phone # 570-296-3569 Fax # 570-296-6055

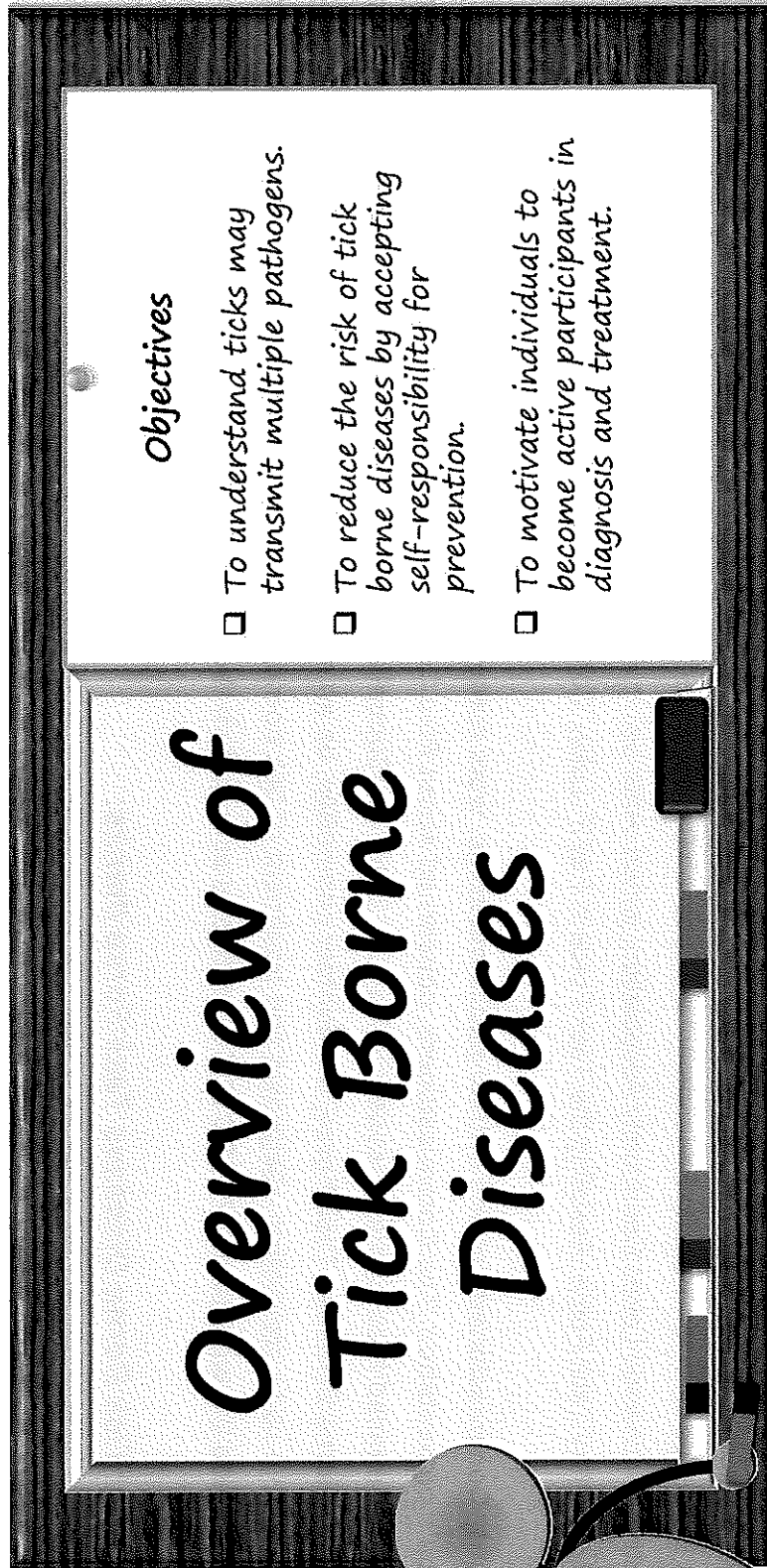

Objectives

- To understand ticks may transmit multiple pathogens.
- To reduce the risk of tick borne diseases by accepting self-responsibility for prevention.
- To motivate individuals to become active participants in diagnosis and treatment.

**Overview of
 Tick Borne
 Diseases**

© 2015 P. LUKIN

Editors: Robert-A. Ollar, PhD, Mikki Weiss, MAEd, Fay P. Lukin, MSEd, PD

ACKNOWLEDGEMENTS

Background: The Pike County Tick Borne Diseases Task Force (PCTBDTF) started as the Pike County Lyme Disease Task Force during a meeting of the minds, in 2013, of Mikki Weiss, Educational Consultant, and Marty Theys, Facilitator, Sussex County Tick Borne Diseases Support Group. They are very well aware of the situation being victims of tick borne diseases. Soon three other members joined: Jim McCaw, Educator; Sandy McCaw, RN, Certified Life Coach, Facilitator of the PCTBDTF Support Group; and Jeff Rosalsky, Executive Director, Pocono Environmental Education Center (PEEC). Shortly afterwards, Clare Bennett, President, Board of Directors, Birchwood Lakes Community Association, joined. After being introduced to microbiologist Robert-A. Ollar, Dr. Ollar, too, joined the voluntary Task Force. Assisting the Task Force is Fay P. Lukin, Communications Consultant.

The Pike County Commissioners, at one of their public meetings, were made aware of the endemic crisis as an outcome of the Task Force's presentation. The Commissioners, concerned about Pike County residents, acknowledged the crisis in the community and embraced it as a county issue. On May 20, 2015, the Commissioners passed a resolution that appointed the Pike County Tick Borne Diseases Task Force, a volunteer committee, as an education arm of the County to provide complete information available as to prevention, diagnosis and treatment of tick borne illnesses. Our Commissioners have been tireless in their efforts to lead the way for the PCTBDTF Committee to accomplish their education goals.

The Pike County Tick Borne Diseases Task Force thanks:

Richard A. Caridi, Pike County Commissioner and Chairman,

Matthew M. Osterberg, Pike County Commissioner, and

Karl A. Wagner, Jr, Pike County Commissioner.

Geographic Distribution

Tick borne diseases have a wide distribution in northern temperate regions of the world. In the United States, the highest incidence occurs in the Northeast, from Maine to Maryland, and the North Central states of Wisconsin and Minnesota.

For tick borne diseases to exist in an area, three elements must be present: high relative humidity at ground level, ticks that carry and transmit pathogens, and animals that provide blood meals for the ticks.

- Ticks are parasites that feed on animal and human blood. Ticks crawl. They cannot fly or jump.
- Ticks live in moist and humid environments, particularly in or near wooded or grassy areas.
- Ticks can be active on days when the ground temperatures are above 40 degrees Fahrenheit.
- Peak time of year for tick activity is from late March to mid-October.



Notes

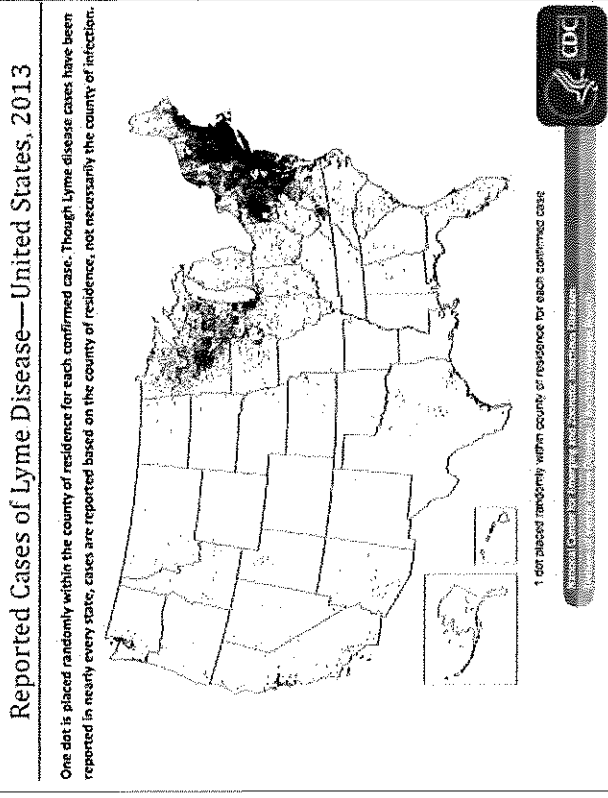

Brief Overview of Pathogens Associated with Tick Borne Diseases

Tick borne diseases are associated with multiple infectious agents. A tick bite can potentially harbor diverse microbial pathogens. It is estimated that up to 20 percent of ticks with *Borrelia burgdorferi* may have one or more other pathogens.

Pathogen	Disease
Anaplasma	Anaplasmosis
Babesia	Babesiosis
Bartonella	Bartonellosis
<i>Borrelia burgdorferi</i>	Lyme disease
<i>Borrelia miyamotoi</i>	Relapsing fever
Ehrlichia	Ehrlichiosis
Flavivirus	Powassan viral encephalitis
<i>Francisella tularensis</i>	Tularemia
<i>Rickettsia rickettsii</i>	Rocky Mountain spotted fever

What one must always keep in mind is that diseases associated with a tick bite are often associated with multiple co-infecting organisms as those cited above. Lyme disease is “only one” infection and *not* a synonym for all infections associated with a tick bite.

How Tick Borne Diseases are Transmitted

Once a tick becomes infected with pathogens it can spread it to humans and animals by biting them. The tick can be attached for hours to days while it engorges itself with blood. As it feeds, its body slowly enlarges. If infected, the tick transmits pathogens into the blood stream. Nymphal ticks are the primary source for transmitting tick borne diseases to humans due to the fact they are rarely noticed because of their size (less than 2 mm).

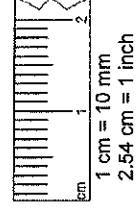
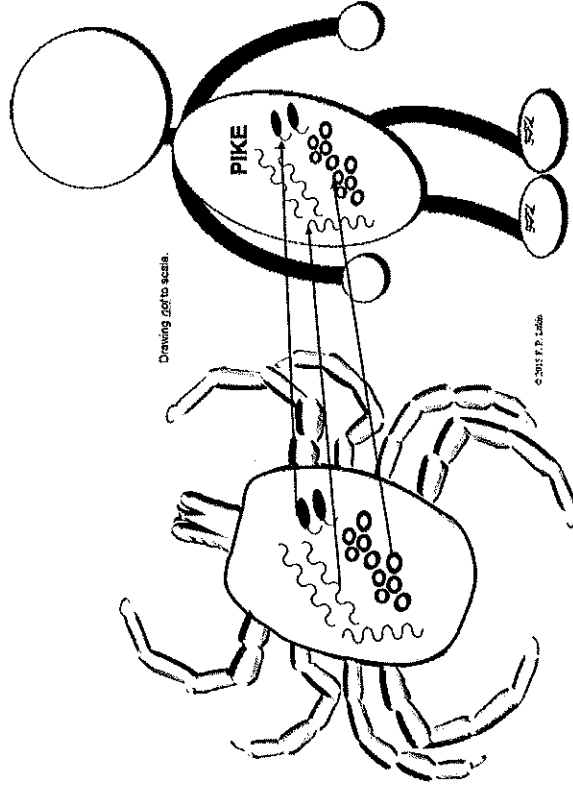

Prevention

- Walk in center of trails to avoid contact with grass and brush.
- Remove leaves, leaf litter and brush around lawns and houses. Remove plants that attract deer from homes.
- Perform frequent, thorough tick checks.
- Wear light colored clothes, a hat, and closed-toe shoes. Tuck pants into socks. Wear a long-sleeved shirt tucked into pants.
- To repel ticks, use products containing DEET for skin and Permethrin for clothes and gear (i.e., backpacks). *Follow label directions.*
- Gear and pets should be checked before bringing into automobiles and/or home.
- When home, tumble clothes in the dryer for 30 minutes to kill ticks.

Don't let Tick Borne diseases get you. Enjoy the great outdoors.
Be "Armed With Knowledge"

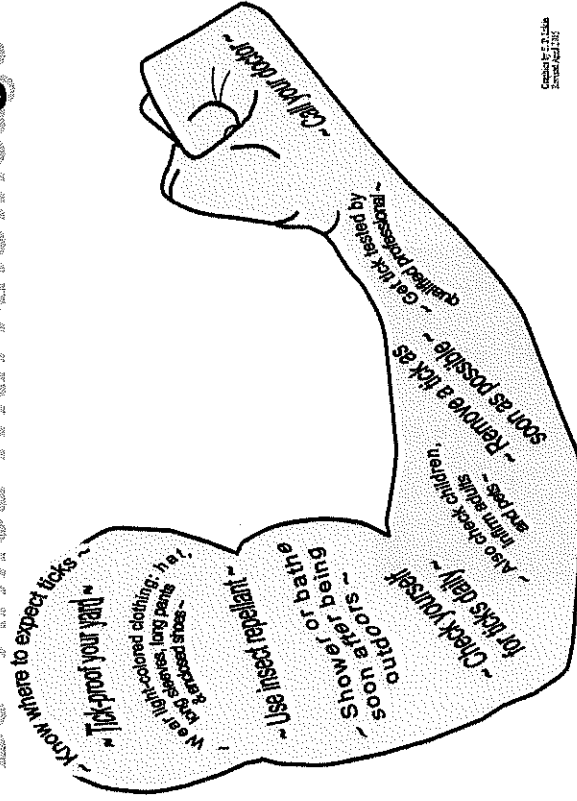

Tick Bite

If you find a tick attached to your skin or if you have the symptoms, consult your physician immediately!!!

Symptoms of Tick Borne Diseases

The early stage of tick borne diseases are usually marked by one or more of the following symptoms: fatigue, chills, fever, headache, muscle and joint pain, swelling in joints, abdominal pain, nausea and vomiting, shortness of breath, palpitations, swollen lymph nodes, rash, numbness, dizziness, unsteady gait, confusion, forgetfulness, disorientation, mood swings, loss of appetite, weakness, and loss of coordination.

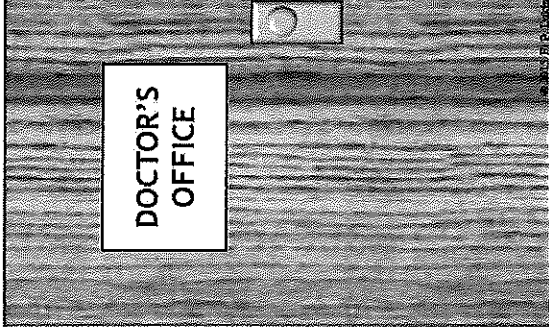
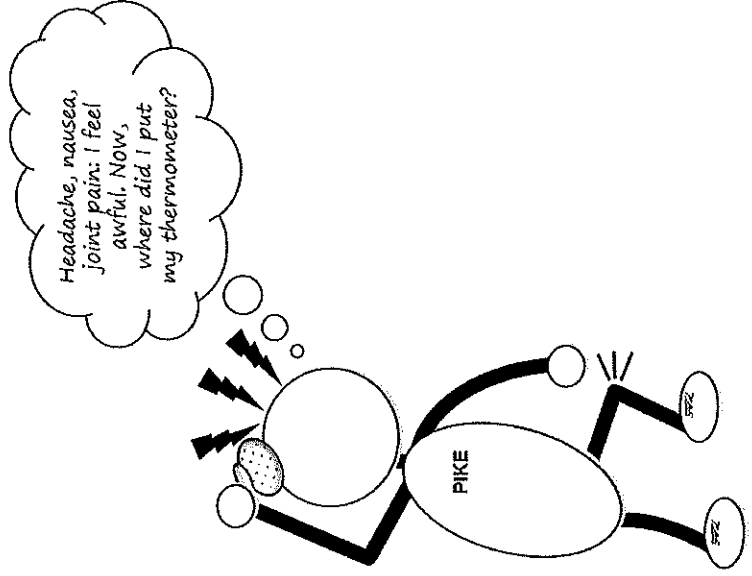

Tick Removal

- Bathe or shower as soon as possible after coming indoors (preferably within two hours). Do a full-body tick check. Tick bites are usually painless.
- If you find a tick, carefully remove the tick with tweezers. Do *not* burn or use any substance to remove tick. Bare hands should not be used to remove ticks, due to the risk of exposure to the tick's fluids or feces. If gloves are not available, the fingers should be shielded with a tissue or paper towel.
- Grasp the tick close to skin with tweezers, pull the tick straight out. Do *not* twist or jerk tick. Make sure you remove the entire tick. After tick removal, use antiseptic on the wound and disinfect the tweezers. Be sure to wash hands thoroughly.
- Save the tick in sealed container. Send tick for testing by a qualified professional.
- If you have been bitten, seek medical care.

NOTE: If you find a tick attached to your skin and you have difficulty removing it or cannot remove it, seek medical help immediately!!

Can Ticks Be Tested?

The tick, after removal from a person, can be tested for the presence of tick borne pathogens by an advanced molecular biology amplification technique called *polymerase chain reaction* (PCR). There are labs throughout Pennsylvania that perform tick testing, such as the *Northeast Wildlife DNA Laboratory* at East Stroudsburg University.

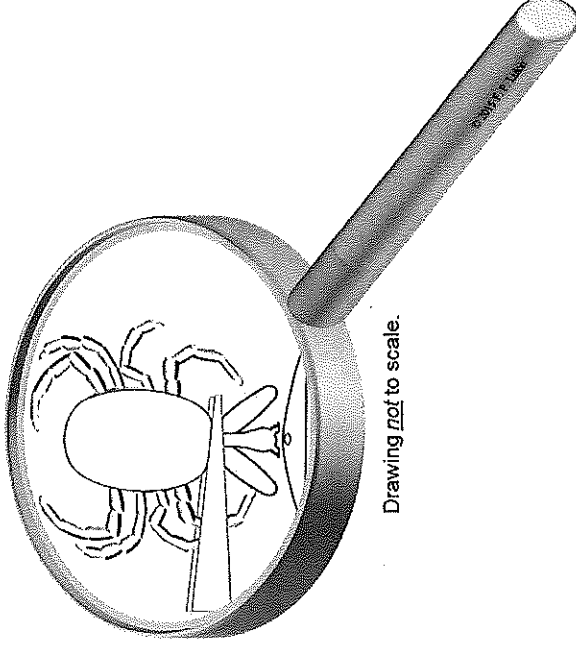

Drawing *not* to scale.

ESU Wildlife DNA Laboratory Website

<http://quantum.esu.edu/dna/links>

Click on "Tick Submission Form" for Instructions

Tests for Tick Borne Pathogens in Humans

The tests currently utilized for identifying tick related pathogens are mostly commonly based upon detecting the antibodies that a person's body develops as a result of an infection from a tick bite.

Immunological Detection Systems

The two mostly commonly utilized immunology based techniques are called *ELISA* and *Western Blot*. These lab tests basically monitor individual's immunological reaction to tick borne pathogens and specific components of same. These lab tests enable a doctor to determine specific tick borne pathogens to which an individual has been exposed.

Genetic Based Amplification Techniques

Gene based systems allow for the rapid detection of tick borne pathogens based upon directly detecting the presence of specific genetic sequences unique to each of the tick borne pathogens. This system utilizes an artificial genetic amplification technique known as *polymerase chain reaction (PCR)*. These genetic based assays are especially most useful in detecting very early infections, because unlike the immunology system, they do not require a patient to first have to develop detectable antibody levels which requires the passage of several weeks.

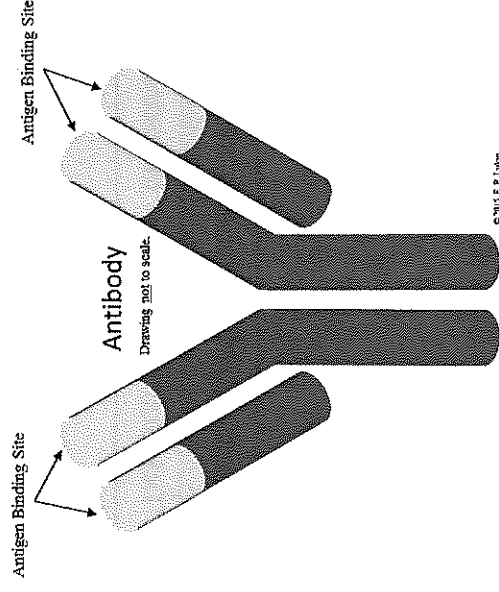

The Structure of DNA

DNA (deoxyribonucleic acid) is a double helix formed by base pairs attached to a sugar-phosphate backbone.

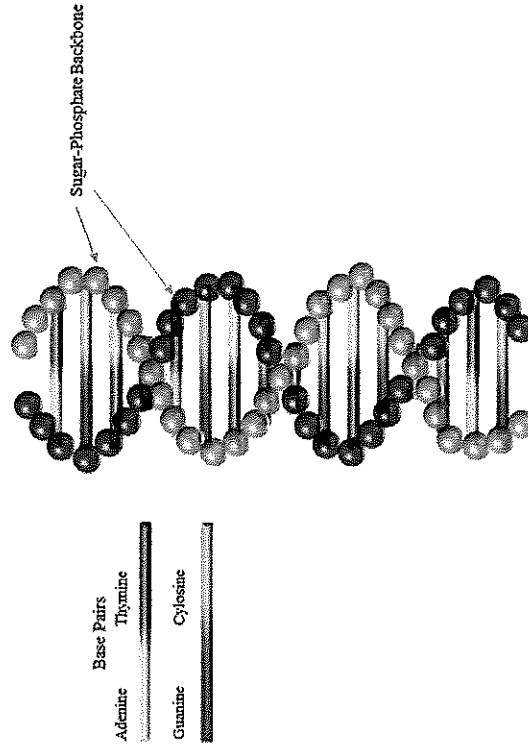

© 2015 Gabbas by F. P. Labin

Treatment

Prevention is the best cure. It is reported that Lyme disease can be treated successfully with antibiotics if caught early in the infection. Patients whose disease is caught later often need to be on antibiotics for longer periods of time. There is controversy as to what is the best mode of treatment. Also, there are antibiotic treatments for Anaplasmosis, Bartonella, Ehrlichiosis, Rocky Mountain spotted fever and Tularemia. There are antiprotozoal agents for treatment of Babesiosis. Currently, there is no treatment available for Powassan virus.

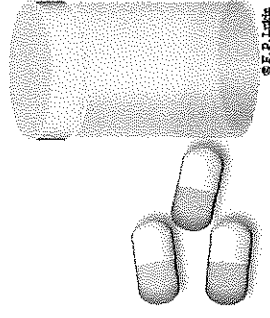

Tick Borne Disease and Pets

Dogs, cats, horses, cows and goats can get tick borne diseases. Perform tick checks to protect your pets. Use veterinarian recommended products.

- Dogs: Symptoms are loss of appetite, excessive sleep, fever, swollen joints, lameness and swollen lymph nodes.
- Cats: Symptoms are loss of appetite, excessive sleep, fever, swollen joints, lameness and swollen lymph nodes.
- Horses: Symptoms are fever, swelling, joint pain, lameness, and eye problems.
- If your animal was bitten, seek veterinary care.

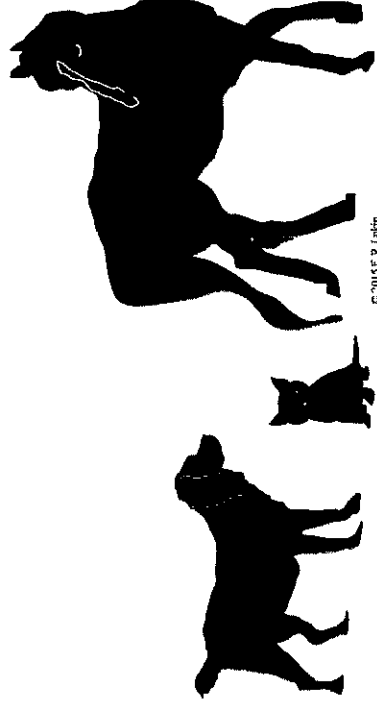

Tick Borne Diseases and Pregnancy

Recent studies of pregnant women infected with *Borrelia burgdorferi*, Lyme disease, have found that the causative agent has the ability to cross the placenta to infect the fetus. These findings have important ramifications and further studies are now in progress. *Therefore, it is important for a pregnant woman with a tick borne infection to be promptly treated and monitored.*

Tick Borne Diseases and Education: It's the Law

There are federal laws that protect students with tick borne diseases. The *Individual with Disabilities Education Act (IDEA)* deals with all students who have some form of disability. Students with tick borne diseases may not be able to participate in regular educational programs and require special educational programs. Anyone who has a physical or mental impairment that substantially limits major life activities is entitled to placement in the regular education environment with the use of supplementary aids and services unless it is demonstrated that education in the regular environment cannot be satisfactorily achieved. Additionally, check state law and school district special education policies.

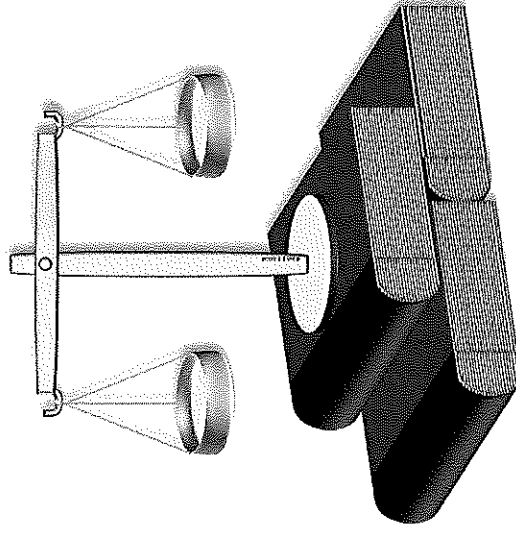

Resources

- Centers for Disease Control and Prevention
 - <http://www.cdc.gov/ticks/diseases>
- National Institute of Allergy and Infectious Diseases
 - <http://www.niaid.nih.gov/topics/tickborne/pages/default.aspx>
- Occupational Safety and Health Administration
 - https://www.osha.gov/SLTC/etools/logging/manual/tick_disease.html
- Pocono Environmental Education Center
 - <http://www.peec.org>

Go to *Resources* and click on *Tick Borne Diseases Task Force*.
- The Pike County Tick Borne Diseases Task Force is on Facebook.
- International Lyme and Associated Diseases Society (ILADS)
 - <http://www.ilads.org>
- LymeDisease.Org
 - <http://www.lymedisease.org>
- Lyme Connection
 - <http://lymeconnection.org>
- Lyme Disease Association of Southeastern Pennsylvania
 - <http://lymepa.org>
- Lyme Disease Association, Inc.
 - <http://www.lymediseaseassociation.org>
- The Infectious Diseases Society of America (IDSA)
 - <http://www.idsociety.org/Index.aspx>

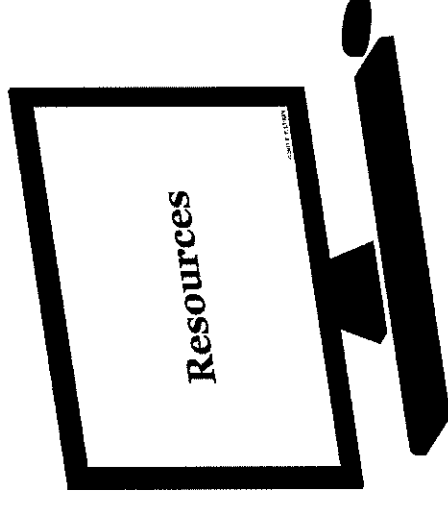

Disclaimer: This booklet is for *educational purposes only*. This does **NOT** substitute for medical advice. If you think you may have a tick borne disease, please contact your doctor.

PREVENTION



If you spend any time outdoors, chances are you are going to come in contact with a tick. By using the following precautions, you can reduce your chances of contracting a tick borne disease.

- Wear light colored clothing.**
(they'll stand out better so you can pick them off)
- Wear pants and a long-sleeve shirt.**
- Tuck your pants into your socks.**
(prevent them from reaching your skin)
- Wear suitable footwear.**
- Apply DEET on skin to repel ticks.**
Products containing Permethrin can be used on clothes and gear.
- Check pets for ticks before entering your home.**
- Check yourself for ticks and shower immediately after coming in from the outdoors.**
- When home, tumble clothes in the dryer for 30 minutes to kill ticks.**
- At home, keep your lawn cut short and keep leaves away from your house.**

www.pikepa.org/tick.html

SUPPORT



4th MONDAY OF EACH MONTH
6:00 PM
PIKE COUNTY LAB & RADIOLOGY SUITE
750 ROUTE 739
LORDS VALLEY, PA 18428
(570) 775-4278

Wayne Memorial Hospital offers a monthly support group for those affected by tick borne diseases.



2nd SATURDAY OF EACH MONTH
10:30 AM - 12:00 PM
PIKE COUNTY PUBLIC LIBRARY
119 HARFORD STREET
MILFORD, PA 18337

Our support group is for people with tick borne diseases and their families.

www.pikepa.org/tick.html



TICK 101

Basic Information

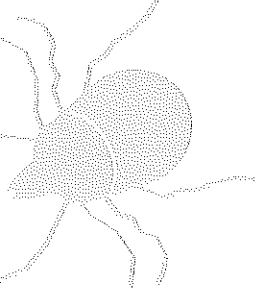

Compliments of the Pike County Commissioners

IDENTIFICATION



Pike County and the surrounding area have Blacklegged Ticks (commonly called Deer Ticks), Dog Ticks, and even Lone Star Ticks.

This image depicts the 3 ticks, in all their stages of development.

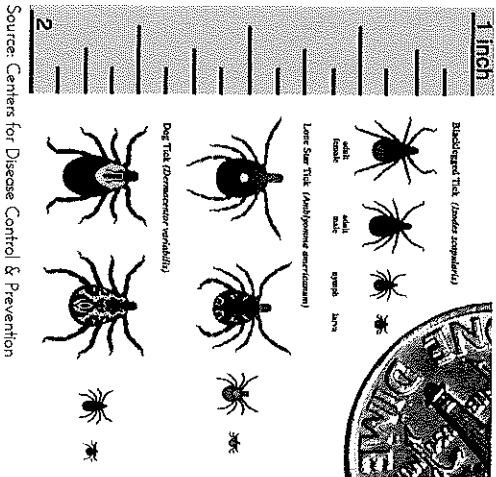

Source: Centers for Disease Control & Prevention

Did You Know?

Pennsylvania has led the nation in confirmed Lyme disease cases each year since 2011.

When detected early, Lyme disease and other tick borne diseases can be treated. Left untreated, tick borne diseases can cause a whole host of problems. Early diagnosis is important in preventing long term complications.

WHERE TO LOOK



After coming inside, always check yourself for ticks. The highlighted areas are prime spots to find a tick as they seek out out-of-the-way crevices and warm spaces. Look closely, they are smaller than a freckle.

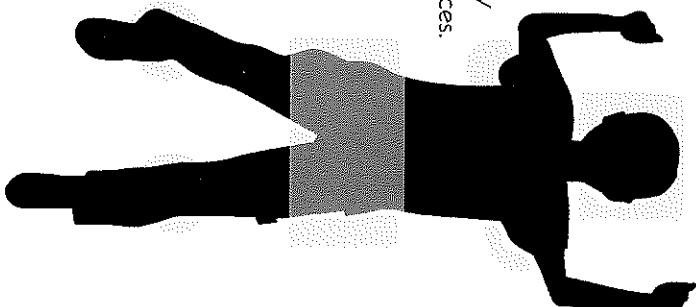

TICK REMOVAL



If a tick does manage to attach itself to you, use fine-tipped tweezers to grasp the tick as close to the skin's surface as possible.

Pull upward with steady, even pressure. Avoid twisting or jerking. Clean the bite area.

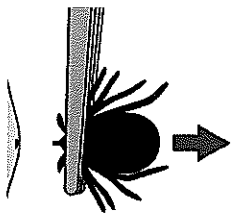

SYMPTOMS



Knowing you have had a tick on you, you might be more alert to watch for symptoms. Unfortunately, many times a tick will bite, feed, and let go before you ever notice it. Below are some common symptoms of a tick infection.

- Fatigue** **Chills**
- Bull's Eye Rash**
(though does not appear in every instance)
- Fever** **Headache**
- Muscle & Joint Pain**
- Rash** **Joint Swelling**

Consult your doctor if you are experiencing any of these symptoms. A blood test can be done to determine if you have a tick borne disease.

TICK TESTING



There are a number of facilities that can test a tick to determine if it was a disease transmitter.

East Stroudsburg University..... (570) 422-7892
Wildlife DNA Laboratory

TickReport..... (413) 545-1057

This information is provided for educational purposes only and is not a substitute for medical advice.

For more complete information, visit our website www.pikepa.org/tick.html